

Mitigation of Greenhouse Gas Emissions from Urban Environmental Infrastructures

Daeseung Kyung, Sunghee Lee, Jongkon Kim

(Ph.D. Daeseung Kyung, Department of Urban Management, Korea Land & Housing Institute, dkyung@lh.or.kr)

(M.S Sunghee Lee, Department of Urban Management, Korea Land & Housing Institute, shiningsh@lh.or.kr)

(Ph.D. Jongkon Kim, Department of Urban Management, Korea Land & Housing Institute, planjk@lh.or.kr)

1 ABSTRACT

The world's population will increase to 9.4 billion people by 2050 and 70% of whom will be living in urban areas. Such urbanization with population growth and industrial development demands in turn create a need for the planning, design, and construction of environmental infrastructures (e.g., water and wastewater treatment plants: WTPs and WWTPs). The environmental infrastructures are essential to provide cities and towns with water supply, waste disposal, and pollution control services.

During the operation of WTPs and WWTPs, massive amount of energy, fuels, and chemicals are consumed. Therefore, they could be major contributors to urban greenhouse gas (GHG) emissions (i.e., 17% of GHGs are generated from water and sewer sector in urban area). To make cities resilient and sustainable, the emission of GHGs from WTPs and WWTPs should be estimated as accurately as possible and effective management plans should be set up as soon as possible.

A comprehensive model was developed to quantitatively estimate on-site and off-site GHGs generated from WTPs and WWTPs. The model was applied to an advanced WTP (treating 200,000 m³/d of raw water with micro-filtration membrane) and a hybrid WWTP (treating 5,500 m³/d of municipal wastewater with five-stage Bardenpho processes). The overall on-site and off-site GHG emissions from the advanced WTP and hybrid WWTP were 0.193 and 2.337 kgCO₂e/d*m³. The major source of GHG generation in the advanced WTP was off-site GHG emissions (98.6%: production of chemicals consumed for on-site use and electricity consumed for unit-process operation). On the other hand, on-site GHG emissions related to biochemical reactions (64%) was the main GHG source of the hybrid WWTP.

Reducing electricity consumption in advanced WTPs could be the best option for generating less GHG emissions and acquiring better water quality. Various options (CO₂ capture and conversion to other useful materials, recovery and reused of CH₄, and operation of WWTPs at optimal conditions) could significantly reduce the total amount of GHG emissions in hybrid WWTPs. The results could be applied to the development of green and sustainable technology, leading to a change in paradigm of urban environmental infrastructure.

Keywords: wastewater treatment plant, water treatment plant, urban environmental infrastructure, greenhouse gas, sustainable technology

2 METHODOLOGY

2.1 System boundary

The system boundaries and the emission pathways of the advanced WTP and hybrid WWTP are demonstrated in Fig. 1 and 2. The system boundary of advanced WTP includes a chemical supply, a rapid mixing, a flocculation, a micro-filtration (MF) membrane, and an ozone disinfection process. In case of the hybrid WWTP, this includes a primary clarifier (PC), a five-stage Bardenpho process [anaerobic (ANAE), first anoxic (ANOX1), first aerobic (AER1), second anoxic (ANOX2), and second aerobic (AER2) stages], a second clarifier (SC), a filter bed (FB), and a ultra-violet disinfection (UVD) process. The baseline task of WTP was treating 200,000 m³/d of raw water with 10 NTU to 0.005 NTU and that of WWTP was dealing with 5,500 m³/d of wastewater (200 mg/L influent BOD) to meet the effluent standard (less than 10 mg/L BOD, 20 mg/L TN, and 0.5 mg/L TP). Typical operating conditions and parameters of the WTP and WWTP in South Korea were used to estimate GHG emissions.

2.2 Estimation of GHG emissions from the WTP and WWTP

There are two types of GHG emissions generated from the WTP and WWTP. We define on-site GHG emissions stem from biochemical reactions in unit processes. Off-site GHG emissions are due to consumption of electricity and fuel for unit process operations as well as for the production and transportation of chemicals for on-site consumption. We developed a comprehensive model for the accurate

estimation of on-site and off-site GHG emissions that could provide a rational basis for tactics useful in establishing sustainable environmental infrastructures.

2.2.1 Estimation of on-site GHG emissions

In case of the WTP, on-site GHG emissions (CO₂) are mainly caused by alkalinity consumption during chemical reactions of coagulants (aluminum sulfate, ferric sulfate, and poly aluminum chloride) and buffers anions (CO₃²⁻ and HCO₃⁻) in mechanical mixing processes. On the other hand, WWTP produce three primary on-site GHGs (CO₂, CH₄, and N₂O) during wastewater treatment, sludge digestion, and system maintenance.

2.2.2 Estimation of off-site GHG emissions

Off-site GHG emissions converted from the consumption of electricity for operating unit processes. The emission factor (0.5584 kgCO₂e/kWh) for electricity use were obtained by considering the portions of power provided by different electric-power sources in South Korea. The amount of GHG emissions related to chemical production and transportation was calculated by multiplying the emission factor of each chemical by its daily consumption.

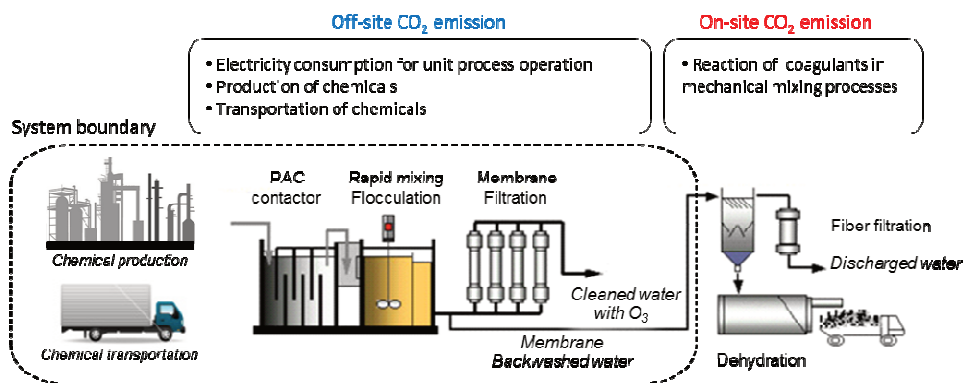

Fig. 1: The system boundary and emission pathway of the advanced WTP

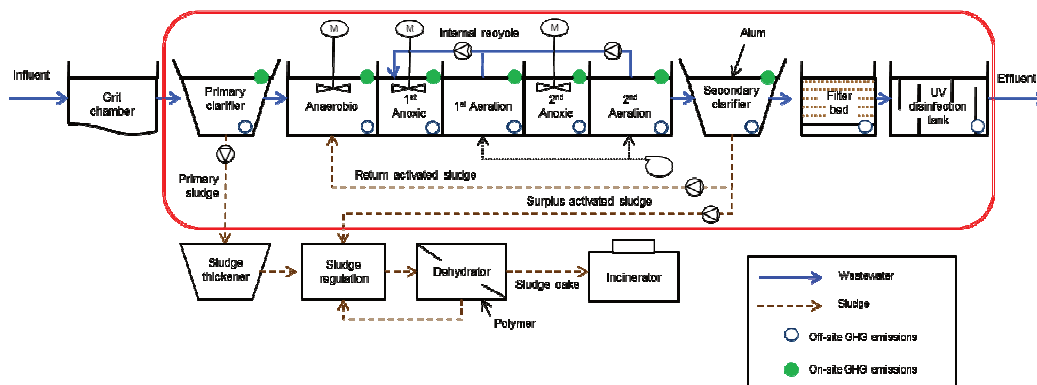

Fig. 2: The system boundary and emission pathway of the hybrid WWTP

3 RESULTS AND DISCUSSION

The GHG emission from each unit process of the advanced WTP under usual operating conditions are shown in Table 1. An enormous amount of electricity was consumed for unit process operations in the advanced WTP, causing it to generate 7,636 ± 1,558 kgCO₂e/d of GHG (19.8% of overall emissions of the plant). The MF membrane process consumed the most electricity, since continuous high pressure (100 kPa) was required for the proper operation of the membrane system. This consumed 6,716 ± 536 kWh/d for filtration and 151 ± 12 kWh/d for backwashing; resulting in 3,835 ± 306 kgCO₂e/d of GHG emission from the process. Ozone disinfection ranked 2nd (2,759 ± 1,107 kgCO₂e/d) for GHG emissions in unit processes, consuming 4,941 ± 1,982 kWh/d electricity to meet the required ozone demand (3mg/L). To keep the ozone feeding concentration constant at 3 mg/L, 704.6 kg of ozone needs to be produced and introduced to the process under 85% ozone transfer rate. Rapid mixing and flocculation in the advanced WTP produced 659 ± 92 and 383 ± 53 kgCO₂e/d of GHG, and consumed 1,181 ± 165 and 686 ± 95 kWh/d of electricity, respectively. On-site GHG emission from the advanced WTP was 395 ± 115 kgCO₂e/d when aluminum sulfate was used as a

coagulant. The on-site GHG emission from the advanced WTP amounted to 1.0% of its overall GHG emissions. Chemical transportation (0.4%) rarely influenced overall GHG emission in the advanced WTP. Reducing electricity consumption in advanced WTPs could be the best option for emitting less GHG emission and getting better water quality. Basic understanding of electricity consumption factors and their impacts can directly contribute to the reduction of CO₂ emissions during advanced WTP operations. It can also be applied to the development of novel water treatment technology with low GHG emissions, as well as for decision-making on GHG emission policies and reduction tactics for WTPs.

Emission type	Category	Emission (kgCO ₂ e/d)	Summation (kgCO ₂ e/d)	Ratio (%)
Off-site GHG emission	Electricity consumption	7,636 ± 2,217	38,197 ± 2,922	19.8
	Chemical production	30,400 ± 1,958		78.8
	Transportation	161 ± 8		0.4
On-site GHG emission	Chemical reaction	395 ± 115	395 ± 115	1.0
Overall GHG emission		38,592 ± 3,005		100

Table 1: The total amount of on-site and off-site GHG emissions from the advanced WTP

The amounts of on-site GHG emissions produced from each unit process in the hybrid WWTP are shown in Table 2. The results showed that AER1 is the major source (7,095±570 kgCO₂e/d) of on-site GHG production in the hybrid WWTP, covering 86.0% of total on-site GHG emissions. This is because the substantial amounts of major GHGs dissolved and accumulated in wastewater and sludge floc, can easily be stripped off and released by aeration. The amount of CO₂ (3,673±265 kgCO₂e/d) and N₂O (2,646±247 kgCO₂e/d) emissions was 4.73 and 3.41 times, respectively, higher than that of CH₄ emissions (776±58 kgCO₂e/d) in these processes. The solubility of CO₂ (0.034 M/atm) and N₂O (0.024 M/atm) was much higher than that of CH₄ (0.0013 M/atm), leading to higher dissolution and accumulation of CO₂ and N₂O than of CH₄ in suspension, and to higher emissions of CO₂ and N₂O during aeration. The second largest on-site GHG emission source was the ANAE (510±36 kgCO₂e/d) process due to high CH₄ emission (497±35 kgCO₂e/d) during the anaerobic degradation of organic materials. Methane could be directly released from wastewater to the atmosphere due to its low solubility and high capacity for mass transfer. Considerable amounts of on-site GHG emissions were also released from PC treating floating organic matter before aeration, and from SC removing soluble organic matter and sludge after aeration, due to substantial removals of carbonaceous materials and nutrients in the processes. On-site GHG production from PC was 366±36 kgCO₂e/d due mainly to CH₄ emission, while that from SC was 252±31 kgCO₂e/d due to N₂O emission. This indicates that the different roles assigned to the unit processes can influence the amount of GHG emissions and their type. Relatively small amounts of GHG emissions were found from ANOX1 (16.8±1.2 kgCO₂e/d), ANOX2 (15.1±3.1 kgCO₂e/d), and AER2 (9.4±1.1 kgCO₂e/d) due to slight removals of carbonaceous materials and nutrients in the processes, and/or substantial GHG emissions from AER1. According to the results above, total on-site GHG emissions related to biochemical reactions at the hybrid WWTP were 8,264±678 kgCO₂e/d. This indicates that considerable amounts of GHGs are generated by biochemical reactions during WWTP operations.

Unit process	CO ₂ emission (kgCO ₂ e/d)	CH ₄ emission (kgCO ₂ e/d)	N ₂ O emission (kgCO ₂ e/d)	Total (kgCO ₂ e/d)
PC	7.7±0.7	287±27	71.2±7.9	366±36
ANAE	1.3±0.1	497±35	11.4±0.8	510±36
ANOX1	1.8±0.2	0.4±0.1	14.6±0.9	16.8±1.2
AER1	3,673±265	776±58	2,646±247	7,095±570
ANOX2	2.1±0.3	0.1±0.0	12.9±2.8	15.1±3.1
AER2	2.3±0.3	0.6±0.1	6.5±0.7	9.4±1.1
SC	13.2±2.0	1.1±0.2	238±29	252±31
Total (kgCO ₂ e/d)	3,701±269	1,562±120	3,001±289	8,264±678

Table 2: The amounts of on-site GHG emissions generated from each unit process in the hybrid WWTP

The total amounts of off-site GHG emissions from the hybrid WWTP, and the percentage contribution of each category, are presented in Table 3. The results showed that the manufacturing of chemicals and their transportation for on-site use is the major source of off-site GHG generation in the hybrid WWTP (2,698±336 kgCO₂e/d), and that this amounts to 58.8% of total off-site GHG emissions (4,591±576 kgCO₂e/d). Among the chemicals, alkaline materials (1,392±186 kgCO₂e/d) and ferric-chloride (1,178±132 kgCO₂e/d) were the main contributors to off-site GHG emissions by chemical production and transportation. This is due to the high GHG emission factor for these chemicals and to the relatively high demand for them during the wastewater treatment processes. This indicates that the methods used to manufacture and convey chemicals for on-site use can significantly influence off-site GHG emissions, and suggests that alternative methods for producing lower amounts of GHGs are required to effectively reduce off-site GHG emissions, without affecting the water quality of the treated effluent. The second greatest GHG off-site emission was due to electric energy consumed for the unit process operations (1,893±240 kgCO₂e/d), covering 41.2% of the total off-site GHG emissions. The GHG emissions related to electricity consumption seem to be directly affected by the efficiency of the operating equipment; therefore enhancement of their efficiency by retrofitting old equipment, as well as by optimizing unit operations and process conditions should significantly reduce off-site GHG emissions from the hybrid WWTP.

Category	Emissions (kgCO ₂ e/d)	Total (kgCO ₂ e/d)	Ratio (%)
Electricity consumption	1,893±240	4,591±576	41.2
Chemical production and transportation	2,698±336		58.8

Table 3: The total amount of off-site GHG emissions from the hybrid WWTP

4 CONCLUSION

The comprehensive model developed in this study made it possible to estimate both on-site and off-site GHG emissions from advanced WTP and hybrid WWTP. GHG emissions were estimated exactly with respect to system type and operating conditions. The patterns of use for each unit-process of the environmental infrastructures were analyzed and tactics to reduce emissions from these processes were suggested. A variety of WTP and WWTP have been built and operated under different operating conditions to properly treat water contaminants. Their optimal types and operation conditions can be changed depending on different water environment scenarios. The model developed in this study cannot compare estimated GHG emissions from entirely different types of WTPs and WWTPs, under different operating conditions; in different water environment scenarios, at this stage. However, the model and estimated results obtained here have provided fundamental knowledge useful to modify its original form to allow estimation of GHG emissions from any kind of WTP and WWTP.

The boundaries of the model can be extended and protocols of the model can be modified to estimate GHG emissions from different WTP and WWTP by adding or deleting a variety of unit processes and associated operating conditions. Additionally, the boundaries of this model can be extended to other environmental and industrial sectors (even to cities and countries) to estimate total GHG emissions. The model can also offer real-time estimation of GHG emission from each unit process in WTP and WWTP with real-time water quality monitoring. This should lead to the development of novel green and sustainable water and wastewater treatment technologies with high contaminant removal efficiency and low GHG emissions. Consideration of GHG emission issues in the urban environmental sector is advancing the understanding of the relationship between quality and GHG. This, in turn, should assist officials in making correct, and now indispensable, public decisions and environmental policy. In the near future, these results might also be applied to develop an optimization model for determination of the proper type and unit processes (with optimal removal efficiency and GHG emissions) under different environmental scenarios.

5 REFERENCES

- Alina, I. R., Bryan, W. K., Christopher, A. K., Andrew, F. C.: Life-cycle energy use and greenhouse gas emissions inventory for water treatment systems. *Journal of Infrastructure Systems*, Vol. 13, Issue 4, pp. 261-270, 2007.
- Bani Shahabadi, M., Yerushalmi, L., Haghghat, F.: Estimation of greenhouse gas generation in wastewater treatment plants - Model development and application. *Chemosphere*, Vol. 78, Issue 9, pp. 1085-1092, 2010.
- Cakir, F. Y., Stenstrom, M. K.: Greenhouse gas production: a comparison between aerobic and anaerobic wastewater treatment technology. *Water Research*, Vol. 39, Issue 17, pp. 4197-4203, 2005.

Kyung, D., Kim, D., Park, N., Lee, W.: Estimation of CO₂ emission from water treatment plant – Model development and application. *Journal of Environmental Management*, Vol. 131, pp. 74-81, 2013.

Kyung, D., Kim, M., Chang, J., Lee, W: Estimation of greenhouse gas emissions from a hybrid wastewater treatment plant. *Journal of Cleaner Production*, Vol. 95, pp. 117-123, 2015.